

BAL-FZ

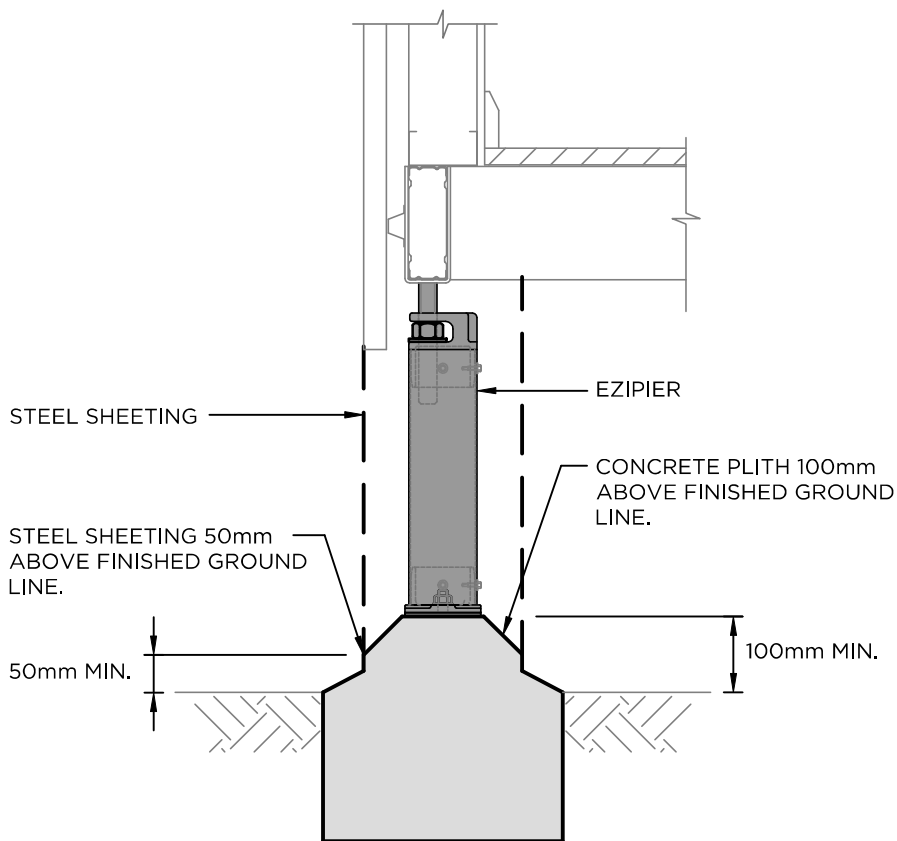
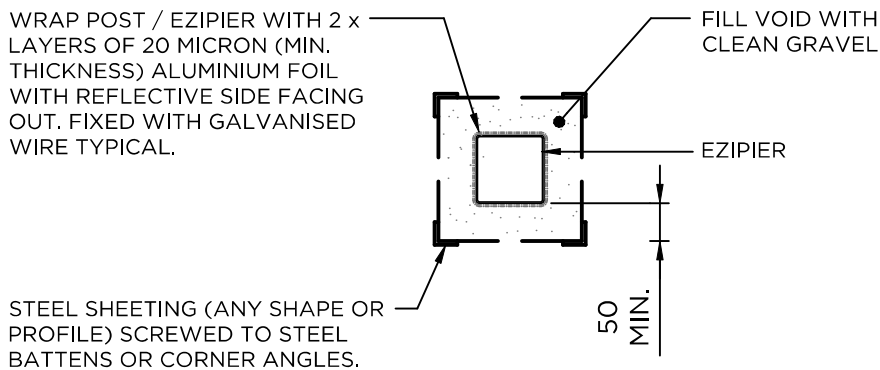

EZIPIER SYSTEM WITH THERMAL BARRIER
OPTION 1: REFLECTIVE FOIL WITH STEEL SHIELD THERMAL BARRIER

TO BE READ IN CONJUNCTION WITH THE FOLLOWING STANDARDS & WEBSITE:
 ● NASH STANDARD STEEL FRAMED CONSTRUCTION IN BUSHFIRE AREAS ● AUSTRALIAN STANDARD AS 3959-2009.
www.spantec.com.au/solutions/building-in-bushfire-prone-areas

| | | | | | |
|---|-------------------------------|-----------|--|------------------------|-------------------------------------|
| SPANTEC <small>SPANTEC SYSTEMS Pty Ltd ABN 56 053 584 384</small> <small>17 Drapers Road Braemar NSW 2575 PO Box 81 Mittagong NSW 2575 Australia Phone 02 4860 1000 Fax 02 4872 1616 www.spantec.com.au</small> | DATE DRAWN 16.05.10 | DWG FILE | JOB DETAILS BOXSPAN STEEL FLOOR FRAMING FOR BUILDING IN BUSHFIRE PRONE AREAS | DESIGNED JPD | JOB REFERENCE Fig 3 A4 |
| | SCALE 1:10 | VIEW NAME | REVISION A | | |